

3 Phase Hi-Torque DC Brushless Motor

42 series, 42x42mm Frame Size

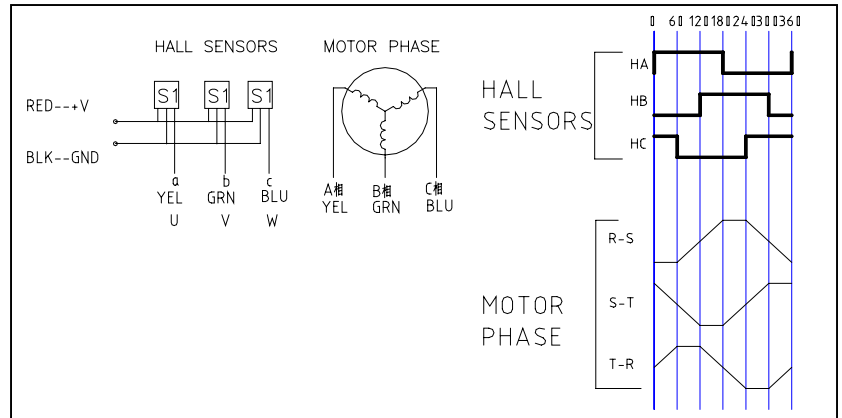

Electrical Specifications:

Model	Rated power	Rated voltage	Current	Number of poles	Rated speed	Torque @ rated speed	Peak torque	Moment constant	Length L	Weight
	W	V DC	A		rpm	N.m	N.m	N.m/A	mm	Kg
42BLDC65A-240	28	24	1.56	8	3000	0.1	0.3	0.06	65	0.45
42BLDC85A-240	63	24	3.44	8	3000	0.2	0.6	0.06	85	0.55

*Note: We can also manufacture products according to customer's requirements.

Dimensions: unit=mm

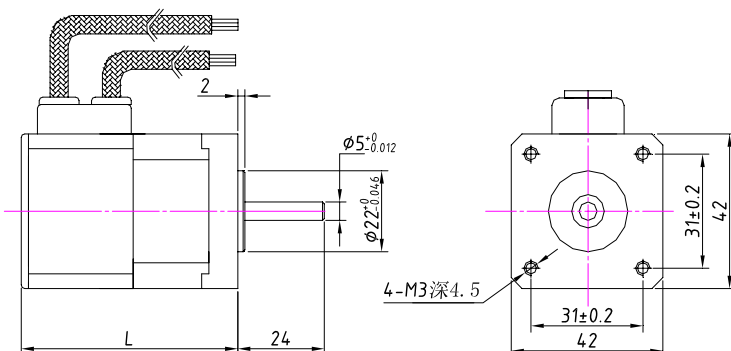

Model	Shaft Diameter D	Shaft Shape
42BLDC60A-240	φ 5	Slick
42BLDC80A-240	φ 5	Slick

3 Phase Hi-Torque DC Brushless Motor

60 series, 61x61mm Frame Size

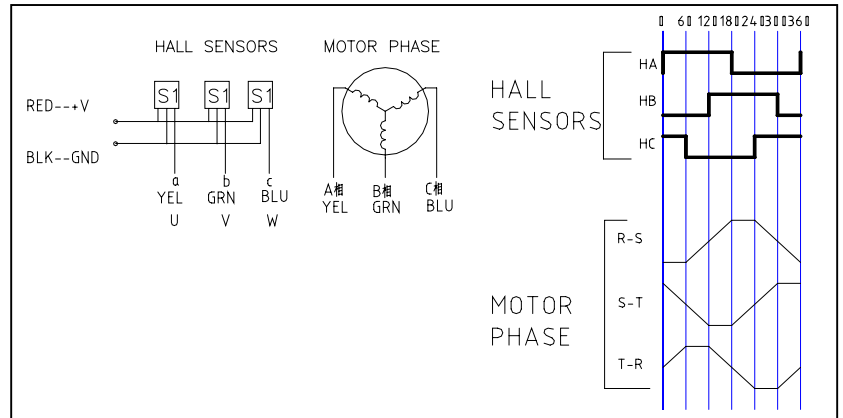

Electrical Specifications:

Model	Rated power	Rated voltage	Current	Number of poles	Rated speed	Torque @ rated speed	Peak torque	Moment constant	Length L	Weight
	W	V DC	A		rpm	N.m	N.m	N.m/A	mm	Kg
60BLDC50A-340	78	36	2.89	8	3000	0.25	0.75	0.09	52	0.9
60BLDC70A-440	156	48	4.33	8	3000	0.5	1.5	0.12	73	1.25
60BLDC90A-640	235	310	1.16	8	3000	0.75	2.25	0.64	94	1.6

*Note: We can also manufacture products according to customer's requirements.

Dimensions: unit=mm

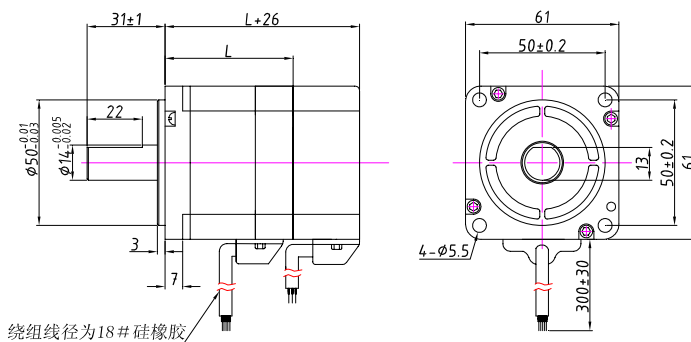

Model	Shaft Diameter D	Shaft Shape
60BLDC50A-350	φ 14	Flat 1x25
60BLDC70A-450	φ 14	Flat 1x25
60BLDC90A-650	φ 14	Flat 1x25

3 Phase Hi-Torque DC Brushless Motor

70 series, 70x70mm Frame Size

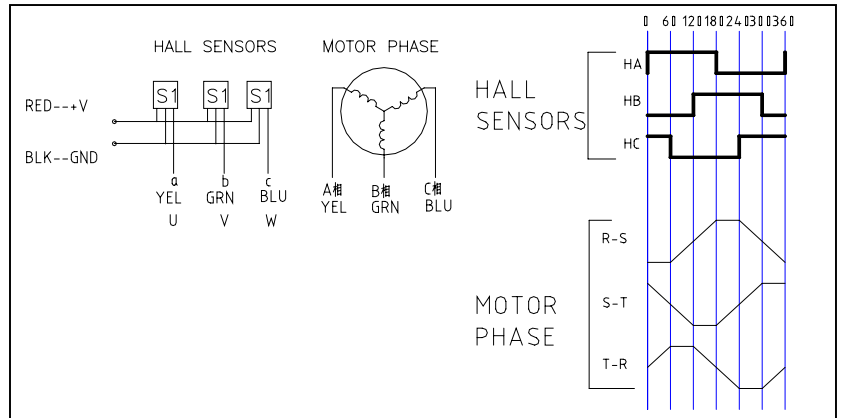
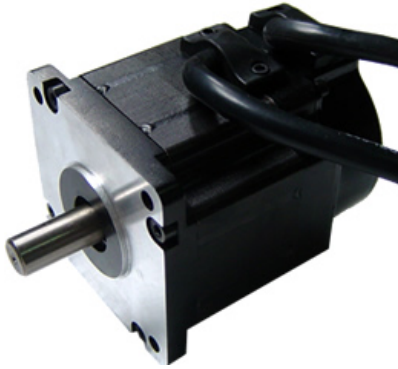

Electrical Specifications:

Model	Rated power	Rated voltage	Current	Number of poles	Rated speed	Torque @ rated speed	Peak torque	Moment constant	Length L	Weight
	W	V DC	A		rpm	N.m	N.m	N.m/A	mm	Kg
70BLDC60A-340	156	36	5.78	8	3000	0.5	1.5	0.09	60	1.3
70BLDC90A-640	313	310	1.44	8	3000	1.0	3.0	0.69	90	2.08

*Note: We can also manufacture products according to customer's requirements.

Dimensions: unit=mm

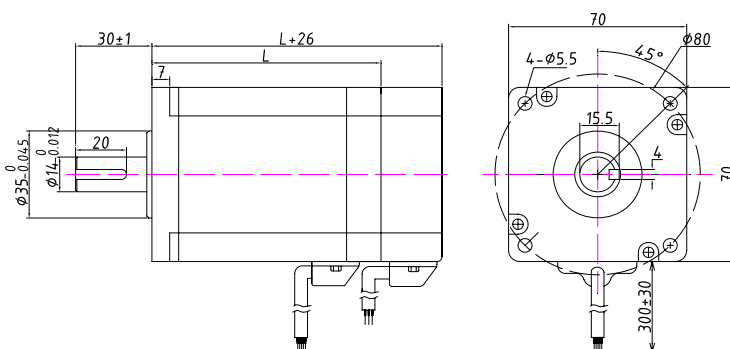

Model	Shaft Diameter D	Shaft Shape
70BLDC60A-340	φ 12	Flat 1x25
70BLDC90A-640	φ 14	Key 4x20

3 Phase Hi-Torque DC Brushless Motor

90 series, 86x86mm Frame Size

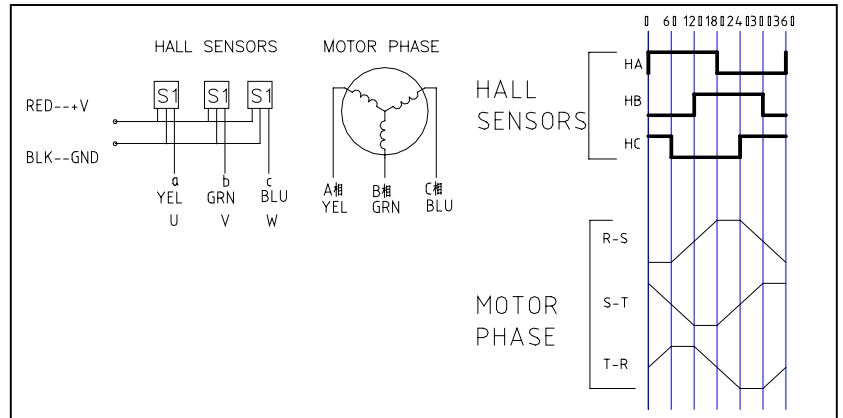

Electrical Specifications:

Model	Rated power	Rated voltage	Current	Number of poles	Rated speed	Torque @ rated speed	Peak torque	Moment constant	Length L	Weight
	W	V DC	A		rpm	N.m	N.m	N.m/A	mm	Kg
90BLDC70A-640x	220	310	0.94	8	3000	0.7	2.1	0.74	71	1.85
90BLDC100A-640x	440	310	1.89	8	3000	1.4	4.2	0.74	100	2.6
90BLDC125A-640x	660	310	2.83	8	3000	2.1	6.3	0.74	125	4

*Note: We can also manufacture products according to customer's requirements.

Dimensions: unit=mm

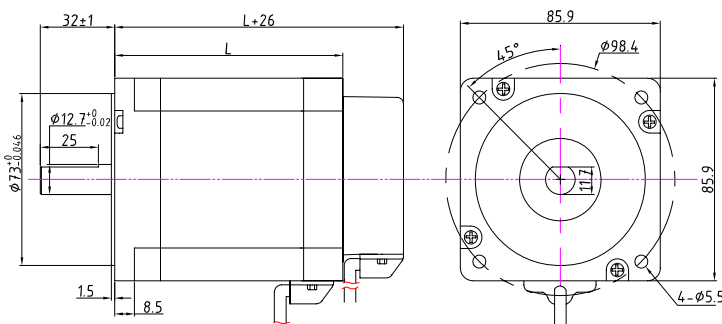

Model	Shaft Diameter D	Shaft Shape
90BLDC70A-640	φ 12.7	Flat 1x25
90BLDC100A-640	φ 12.7	Flat 1x25
90BLDC125A-640	φ 14	Flat 1x25

3 Phase Hi-Torque DC Brushless Motor

110 series, 110x110mm Frame Size

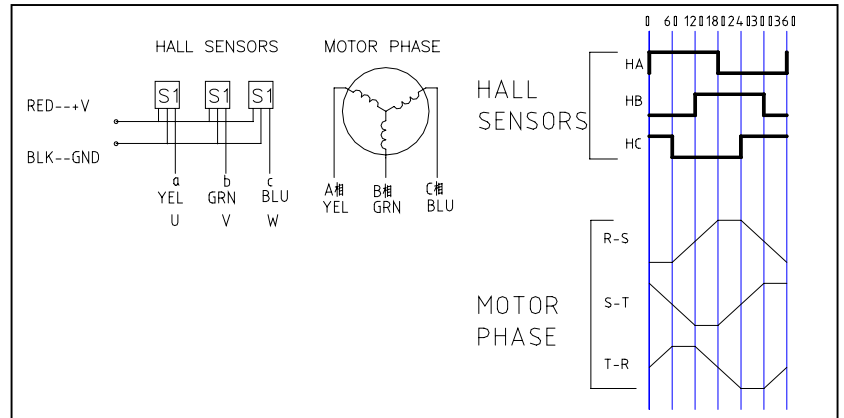

Electrical Specifications:

Model	Rated power	Rated voltage	Current	Number of poles	Rated speed	Torque @ rated speed	Peak torque	Moment constant	Length L	Weight
	W	V DC	A		rpm	N.m	N.m	N.m/A	mm	Kg
110BLDC110A-640x	940	310	4.33	8	3000	3	9	0.69	113	4.5
110BLDC170A-630x	1250	310	5.76	8	2000	6	18	1.04	173	7

*Note: We can also manufacture products according to customer's requirements.

Dimensions: unit=mm

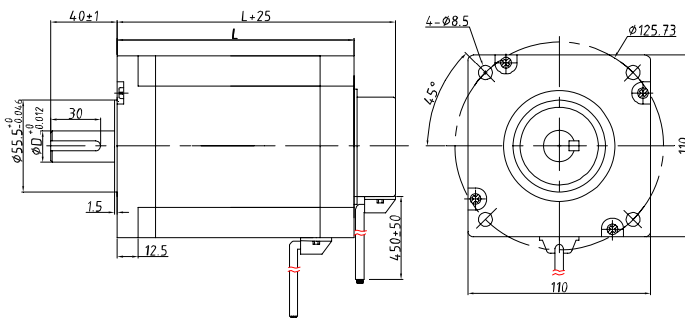

Model	Shaft Diameter D	Shaft Shape
110BLDC110A-640x	$\phi 19$	Key 6X30
110BLDC170A-630x	$\phi 19$	Key 6X30