

User's Manual

For

3L883M

Extremely Low Noise 3-phase Microstepping Driver

Version 1.0

©2008 All Rights Reserved

Attention: Please read this manual carefully before using the driver!



MotionKing(China) Motor Industry Co., Ltd.

T: (86)519-8988 6261 F: (86)519-8515 1172

Web site: www.MotionKing.com E-Mail: sales@MotionKing.com

The content in this manual has been carefully prepared and is believed to be accurate, but no responsibility is assumed for inaccuracies.

MotionKing reserves the right to make changes without further notice to any products herein to improve reliability, function or design. MotionKing does not assume any liability arising out of the application or use of any product or circuit described herein; neither does it convey any license under its patent rights of others.

MotionKing's general policy does not recommend the use of its products in life support or aircraft applications wherein a failure or malfunction of the product may directly threaten life or injury. According to MotionKing's terms and conditions of sales, the user of MotionKing's products in life support or aircraft applications assumes all risks of such use and indemnifies MotionKing against all damages.

©2008 by MotionKing

All Rights Reserved

Table of Contents

1. Introduction, Features and Applications 1
 Introduction 1
 Features 1
 Applications..... 1
 2. Specifications and Operating Environment 1
 Electrical Specifications 1
 Operating Environment 2
 Mechanical Specifications..... 2
 Elimination of Heat 3
 3. Pin Assignment and Description 3
 Connector P1 Configurations 3
 Selecting CW/CCW or PUL/DIR Mode..... 4
 Connector P2 Configurations 4
 4. Connections to Controller..... 4
 5. Connections to Stepping Motors 5
 6. Power Supply Selection..... 6
 Regulated or Unregulated Power Supply 6
 Multiple Drivers 6
 Selecting Supply Voltage:..... 7
 7. Output Current and Microstep Resolution Settings..... 7
 Current Setting 7
 DIP Setting for Dynamic Current 7
 DIP Setting for Standstill Current..... 8
 Microstep Resolution Setting 8
 8. Wiring Notes..... 9
 9. Typical Connection..... 9
 10. Sequence Chart of Control Signals..... 10
 11. Protection Functions 11
 Over-voltage Protection..... 11
 Short-voltage Protection 11

Short Circuit Protection..... 11
 Over-current Protection 11
 Over-temperature Protection 11
 12. Frequently Asked Questions..... 11
 Problem Symptoms and Possible Causes 12

1. Introduction, Features and Applications

Introduction

The 3L883M is a high resolution 3-phase microstepping driver based on precision current control technology. It's suitable for driving 3-phase hybrid stepping motors from NEMA size 17 to 34. By using the advanced pure-sinusoidal current control technology, both the noise and vibration of the stepping motor have been greatly reduced, which makes the stepping motors offer servo-like performances. Compared to the 3ND583, it has broader supply voltage range and offers more microstep resolutions, thus can be used to replace more 2-phase stepping systems directly without changing application software, offering better performances. And compared to most of the microstepping drivers in the market, both driver heating and motor heating have been reduced by 15-30%.

Features

- High performance, low noise and lost cost
- Low driver heating and low motor heating
- Supply voltage up to 80 VDC
- Output current up to 8.3A (RMS 5.9A)
- Input signal TTL compatible
- Automatic idle-current reduction
- Suitable for 3-phase stepping motors, including 3 lead and 6 lead motors
- Optically isolated differential input signals,
- pulse frequency up to 300 KHz
- 16 selectable resolutions up to 25600 steps/rev
- DIP switch current setting with 8 different values
- PUL/DIR & CW/CCW modes optional
- Over-voltage, short-voltage, over-current , and over-temperature protection
- Small size for easy mounting

Applications

Suitable for a wide range of 3-phase stepping motors from NEMA size 17 to 34. It can be used in various kinds of machines, such as X-Y tables, labeling machines, laser cutters, engraving machines, and pick-place devices, and etc. It's extremely suitable for the applications desired with low noise, low vibration, high speed and high precision.

2. Specifications and Operating Environment

Electrical Specifications (T_j=25°C)

Parameters	3L883M			Unit
	Min	Typical	Max	
Output current	2.1	-	8.3 (5.9 RMS)	A

Supply voltage	24	68	80	VDC
Logic signal current	7	10	16	mA
Pulse input frequency	0	-	300	KHz
Isolation resistance	500			MΩ

Operating Environment

Cooling	Natural cooling or forced cooling	
Operating Environment	Environment	Avoid dust, oil fog and corrosive gases
	Ambient Temperature	0°C — +50°C
	Operating Temperature	70°C
	Humidity	40—90%RH
	Vibration	5.9m/s ² Max
Storage Temperature	-20°C — +125°C	
Weight	Approx. 550 gram (19.4 oz)	

Mechanical Specifications (unit=mm, 1 inch = 25.4 mm)

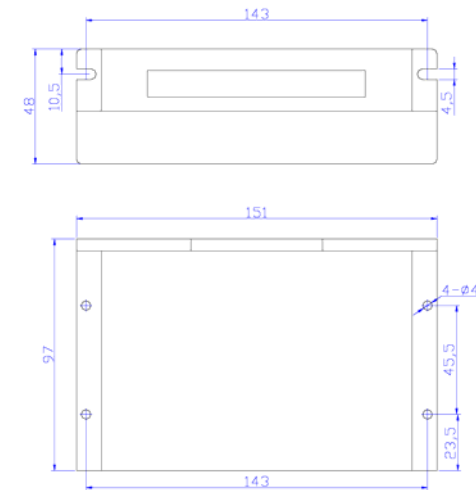

Figure 1: Mechanical Specifications

*Recommend use side mounting for better heat dissipation.

Elimination of Heat

- Driver’s reliable working temperature should be <65°C, and motor working temperature should be <80°C;
- Recommend use automatic idle-current reduction mode, namely current automatically be reduced to 60% when motor stops, so as to reduce driver heating and motor heating.

3. Pin Assignment and Description

The 3L883M has two connectors, connector P1 for control signals connections, and connector P2 for power and motor connections. The following tables are brief descriptions of the two connectors. More detailed descriptions of the pins and related issues are presented in section 4, 5, 9.

Connector P1 Configurations

Pin Function	Details
PUL+(+5V)	<u>Pulse signal</u> : In single pulse (pulse/direction) mode, this input represents pulse signal, effective for each rising edge or falling edge (set by inside jumper J1); 4-5V when PUL-HIGH, 0-0.5V when PUL-LOW. In double pulse mode (pulse/pulse) this input represents clockwise (CW) pulse. For reliable response, pulse width should be longer than 1.5μs. Series connect resistors for current-limiting when +12V or +24V used.
PUL-(PUL)	
DIR+(+5V)	<u>DIR signal</u> : In single-pulse mode, this signal has low/high voltage levels, representing two directions of motor rotation; in double-pulse mode (set by inside J1 jumper), this signal is counter-clock (CCW) pulse, effective for low level. For reliable motion response, DIR signal should be ahead of PUL signal by 5μs at least. 4-5V when DIR-HIGH, 0-0.5V when DIR-LOW.
DIR-(DIR)	
ENA+(+5V)	<u>Enable signal</u> : This signal is used for enabling/disabling the driver. High level (NPN control signal, PNP and Differential control signals are on the contrary, namely Low level for enabling.) for enabling the driver and low level for disabling the driver. Usually left UNCONNECTED (ENABLED) .
ENA-(ENA)	

Notes: PUL/DIR mode is the default mode, and under-cover jumper J1 can be used to switch it to CW/CCW mode.

Selecting CW/CCW or PUL/DIR Mode

There is a jumper J1 (including pin 1 to pin 9) inside the 3L883M specifically for selecting pulse signal mode. Settings for the one-pulse mode (PUL/DIR) and for the double-pulse mode (CW/CCW) are shown in the following figure. Default mode out of factory is PUL/DIR mode and effective at rising edge.

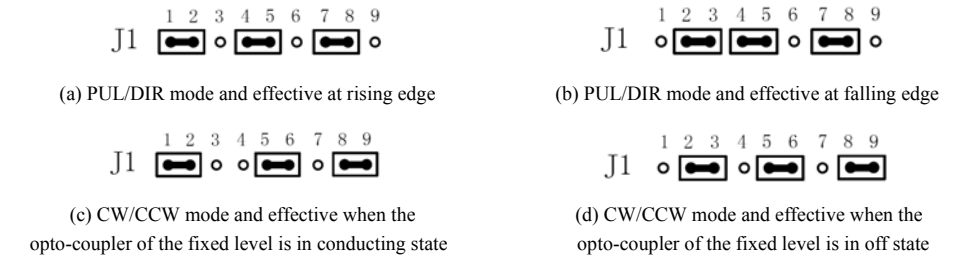

Figure 2: Control signal mode setting jumper

Notes: For (c), the user should move R137 (a 0Ω resistor) to R136 besides setting J1, and let R137 NC (open circuit).

Connector P2 Configurations

Pin Function	Details
GND	DC power ground
VDC	DC power supply, +24VDC—+80VDC, Including voltage fluctuation and EMF voltage.
U	Motor phase U
V	Motor phase V
W	Motor phase W

Remark: Please note that motion direction is also related to motor-driver wiring matches. Exchanging the connections of two phases to the driver will reverse motor motion direction.

4. Connections to Controller

The 3L883M can accept differential and single-ended control signals (including open-collector, namely common-anode and PNP output, namely common-cathode). The 3L883M has 3 optically isolated logic inputs which are located on connector P1 to accept line driver control signals. These inputs are isolated to minimize or eliminate electrical noises coupled onto the control signals. It’s recommended to use line driver control signals to increase noise immunity of the driver under an

interference environment. Connections to open-collector and PNP signals are illustrated in the figure 3 and the figure 4.

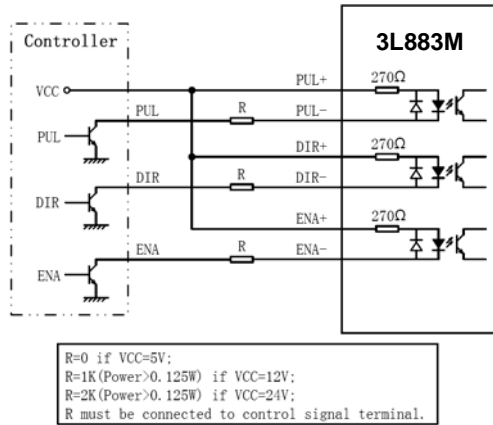

Figure 3: Connections to open-collector signal (common-anode)

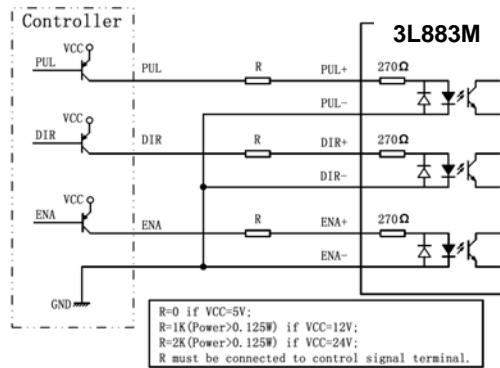

Figure 4: Connections to PNP signal (common-cathode)

5. Connections to Stepping Motors

The connection between the driver and 3-phase stepping motors includes two different kinds of connections, namely delta-connection and star-connection. Using delta-connection, the performances of the motor under high speed condition are better, but the driver current is higher too (about 1.73 times the motor coil current); while using star-connection, the driver current equals

to the motor coil current.

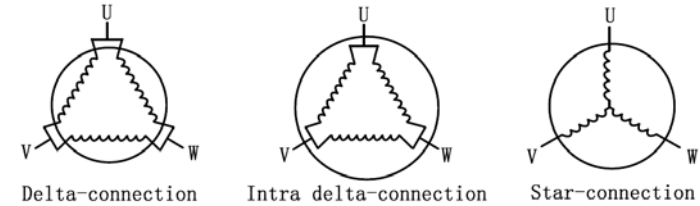

Figure 5: Motor connections

6. Power Supply Selection

The 3L883M can match medium and small size stepping motors (from NEMA size 17 to 34) made by MotionKing or other motor manufactures around the world. To achieve good driving performances, it is important to select supply voltage and output current properly. Generally speaking, supply voltage determines the high speed performance of the motor, while output current determines the output torque of the driven motor (particularly at lower speed). Higher supply voltage will allow higher motor speed to be achieved, at the price of more noise and heating. If the motion speed requirement is low, it's better to use lower supply voltage to decrease noise, heating and improve reliability.

Regulated or Unregulated Power Supply

Both regulated and unregulated power supplies can be used to supply the driver. However, unregulated power supplies are preferred due to their ability to withstand current surge. If regulated power supplies (such as most switching supplies.) are indeed used, it is important to have large current output rating to avoid problems like current clamp, for example using 4A supply for 3A motor-driver operation. On the other hand, if unregulated supply is used, one may use a power supply of lower current rating than that of motor (typically 50%~70% of motor current). The reason is that the driver draws current from the power supply capacitor of the unregulated supply only during the ON duration of the PWM cycle, but not during the OFF duration. Therefore, the average current withdrawn from power supply is considerably less than motor current. For example, two 3A motors can be well supplied by one power supply of 4A rating.

Multiple Drivers

It is recommended to have multiple drivers to share one power supply to reduce cost, if the supply has enough capacity. To avoid cross interference, **DO NOT** daisy-chain the power supply input

pins of the drivers. (Instead, please connect them to power supply separately.)

Selecting Supply Voltage:

The power MOSFETS inside the 3L883M can actually operate within +24~+80VDC, including power input fluctuation and back EMF voltage generated by motor coils during motor shaft deceleration. Higher supply voltage can increase motor torque at higher speeds, thus helpful for avoiding losing steps. However, higher voltage may cause bigger motor vibration at lower speed, and it may also cause over-voltage protection or even driver damage. Therefore, it is suggested to choose only sufficiently high supply voltage for intended applications, and it is suggested to use power supplies with theoretical output voltage of +24~+ 72V, leaving room for power fluctuation and back-EMF.

7. Output Current and Microstep Resolution Settings

Current Setting

For a given motor, higher driver current will make the motor output more torque, but at the same time causes more heating in the motor and driver. Therefore, output current is generally set to be such that the motor will not overheat for long time operation. Phase current rating supplied by motor manufacturer is important in selecting driver current, however the selection also depends on leads and connections.

DIP Setting for Dynamic Current

The 3L883M uses an 8-bit DIP switch to set motor dynamic current, standstill current and microstep resolution, as shown below:

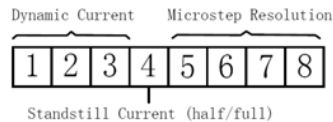

The first three bits (SW1, 2, 3) of the DIP switch are used to set the dynamic current. Select a setting closest to your motor's required current.

Peak current (A)	RMS (A)	SW1	SW2	SW3
2.2A	1.6A	OFF	OFF	OFF
3.1A	2.2A	ON	OFF	OFF
3.9A	2.8A	OFF	ON	OFF
4.8A	3.4A	ON	ON	OFF
5.7A	4.1A	OFF	OFF	ON

6.6A	4.7A	ON	OFF	ON
7.4A	5.3A	OFF	ON	ON
8.3A	5.9A	ON	ON	ON

Notes: Due to motor inductance, the actual current in the coil may be smaller than the dynamic current settings, particularly under high speed condition.

DIP Setting for Standstill Current

SW4 is used for this purpose. OFF meaning that the standstill current is set to be half of the selected dynamic current, and ON meaning that standstill current is set to be the same as the selected dynamic current. The current automatically reduced to 60% of the selected dynamic current 0.5 second after the last pulse when use automatic idle-current reduction mode. Theoretically, this will reduce motor heating to 36% (due to $P=I^2 \cdot R$) of the original value.

Microstep Resolution Setting

Microstep resolution is set by SW5, 6, 7, 8 of the DIP switch as shown in the following table:

Steps/rev.(for 1.2°motor)	SW5	SW6	SW7	SW8
200	ON	ON	ON	ON
400	OFF	ON	ON	ON
1600	ON	OFF	ON	ON
3200	OFF	OFF	ON	ON
6400	ON	ON	OFF	ON
12800	OFF	ON	OFF	ON
25600	ON	OFF	OFF	ON
500	OFF	OFF	OFF	ON
1000	ON	ON	ON	OFF
1200	OFF	ON	ON	OFF
2000	ON	OFF	ON	OFF
4000	OFF	OFF	ON	OFF
5000	ON	ON	OFF	OFF

6000	OFF	ON	OFF	OFF
8000	ON	OFF	OFF	OFF
10000	OFF	OFF	OFF	OFF

8. Wiring Notes

- In order to improve anti-interference performance of the driver, it is recommended to use twisted pair shield cable.
- To prevent noise incurred in pulse/dir signal, pulse/direction signal wires and motor wires should not be tied up together. It is better to separate them by at least 10 cm, otherwise the disturbing signals generated by motor will easily disturb pulse direction signals, causing motor position error, system instability and other failures.
- If a power supply serves several drivers, separately connecting drivers is recommended instead of daisy-chaining.
- It is prohibited to pull and plug connector P2 while the driver is powered ON, because there is high current flowing through motor coils (even when motor is at standstill). Pulling or plugging connector P2 with power on will cause extremely high back-EMF voltage surge, which may damage the driver.

9. Typical Connection

A complete stepping system should include stepping motor, stepping driver, power supply and controller (pulse generator). A typical connection is shown in the Figure 6.

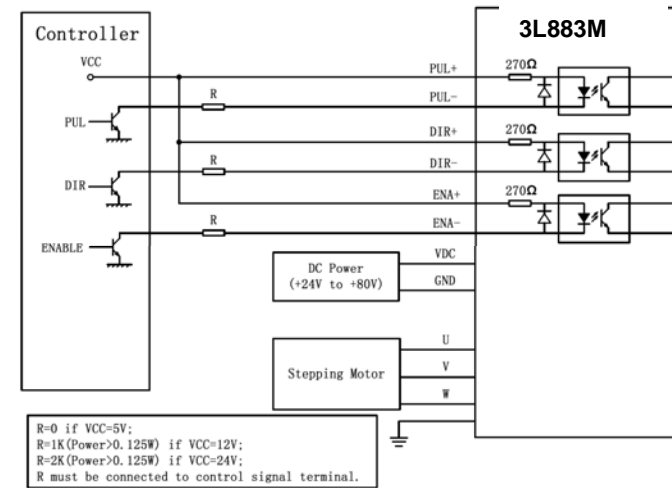

Figure 6: Typical connection

10. Sequence Chart of Control Signals

In order to avoid some fault operations and deviations, PUL, DIR and ENA signals should abide by some rules, as shown in the figure 7:

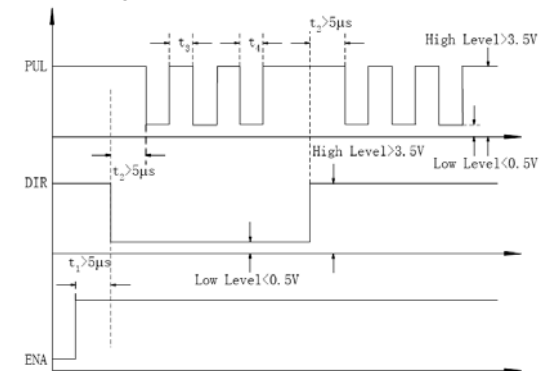

Figure 7: Sequence chart of control signals

Remark:

- (1) t_1 : ENA must be ahead of DIR by at least $5\mu s$. Usually, ENA+ and ENA- are NC (not connected). See “Connector P1 Configurations” for more information.
- (2) t_2 : DIR must be ahead of PUL effective falling edge by at least $5\mu s$ to ensure correct

direction;

- (3) t_3 : Pulse width not less than 1.5 μ s;
- (4) t_4 : Low level width not less than 1.5 μ s.

11. Protection Functions

To improve reliability, the driver incorporates some built-in protection features.

Over-voltage Protection

When power supply voltage exceeds +91VDC, protection will be activated and the LED will turn red.

Short-voltage Protection

When power supply voltage is lower than +16VDC, protection will be activated and the LED will turn red.

Short Circuit Protection

Protection will be activated in case of short circuit between motor coil and ground. When short circuit protection function is active, the LED will turn red.

Over-current Protection

Protection will be activated in case of over current which may otherwise damage the driver.

Over-temperature Protection

Protection will be activated in case of the temperature of the driver reaches 75°C \pm 5°C, and the LED will turn red.

Attention: Since there is no protection against power leads (+, -) reversal, it is critical to make sure that power supply leads correctly connected to the driver. Otherwise, the driver will be damaged instantly. When protection function is active, the user should **REPOWER** the driver to reset the driver.

12. Frequently Asked Questions

In the event that your driver doesn't operate properly, the first step is to identify whether the problem is electrical or mechanical in nature. The next step is to isolate the system component that is causing the problem. As part of this process you may have to disconnect the individual

components that make up your system and verify that they operate independently. It is important to document each step in the troubleshooting process. You may need this documentation to refer back to at a later date, and these details will greatly assist our Technical Support staff in determining the problem should you need assistance.

Many of the problems that affect motion control systems can be traced to electrical noise, controller software errors, or mistake in wiring.

Problem Symptoms and Possible Causes

Symptoms	Possible Problems
Motor is not rotating	No power
	Microstep resolution setting is wrong
	DIP switch current setting is wrong
	Fault condition exists
	The driver is disabled
Motor rotates in the wrong direction	Motor phases may be connected in reverse
The driver in fault	DIP switch current setting is wrong
	Something wrong with motor coil
Erratic motor motion	Control signal is too weak
	Control signal is interfered
	Wrong motor connection
	Something wrong with motor coil
	Current setting is too small, losing steps
Motor stalls during acceleration	Current setting is too small
	Motor is undersized for the application
	Acceleration is set too high
	Power supply voltage too low
Excessive motor and driver heating	Inadequate heat sinking / cooling
	Automatic current reduction function not being utilized
	Current is set too high

